

ASAHI

Cat. No.BE04-13



JQA-1973
JQA-EM4783



Stainless Steel Insert Ball Bearing Units

- MUCP200V,Y
- MUCF200V,Y
- MUCFL200V,Y
- MUCT200V,Y
- MUCPA200V,Y
- MUCFC200V,Y



AVAILABLE
UP TO
65mm

ASAHI SEIKO CO., LTD.

ASAHI stainless steel ball bearing units provide the excellent corrosion resistance as well as self-alignment; all stainless steel insert bearings incorporated with stainless cast steel housings. The insert bearing is lubricated with NSF H-1 food grade grease as standard, and also available with heat-resistant lubricant for the stable performance at high temperature. The housing is renewed with beautiful surface and solid base suitable for the hygienically clean environment by the lost wax casting process. This series can be also served with stainless steel covers on request for steady protection against dusty conditions.

Feature 1 Excellent corrosion resistance

Both insert bearing and housing are made of stainless steel and suitable for various harsh environments.

Feature 2 Best for food processing machines

Insert bearing MUC200V type conforms to the RoHS Directive and is lubricated with NSF H-1 food grade grease as standard.

Feature 3 Dimensionally interchangeable with the ordinary JIS types

Insert bearing MUC type is interchangeable with UC type.

Feature 4 Good looking housing with solid base

Housing characterized by smooth surface and solid base is ideal for creating and maintaining the hygienically clean environment.

Feature 5 Stainless steel covers are available

For harsh condition, stainless steel covers are available on request.

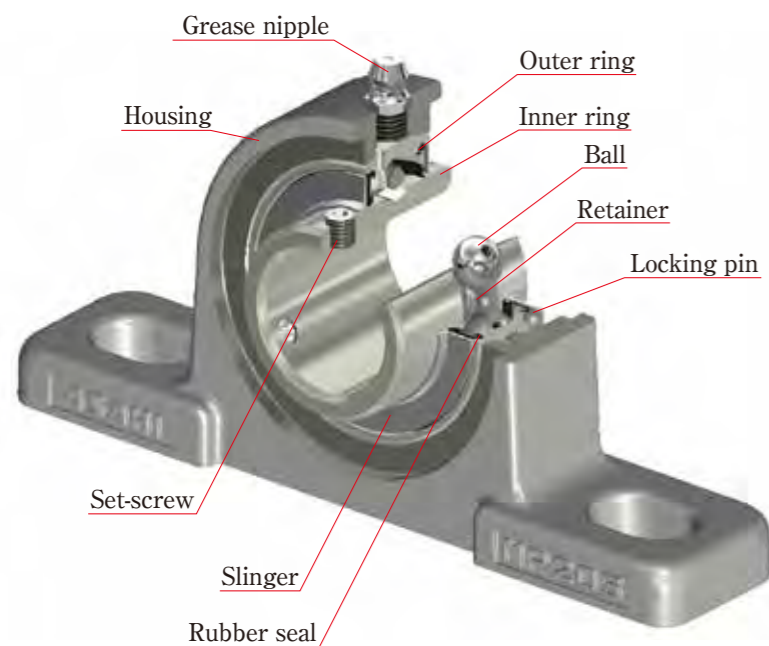

Unit with open covers



Unit with open and closed covers

MATERIAL

Parts		Material	
Bearing	Inner & outer rings	Stainless steel	SUS440C (equiv.)
	Locking pin	Stainless steel	SUS440C
	Balls	Stainless steel	SUS440C
	Slinger	Stainless steel	SUS304
	Retainer	Stainless steel	SUS304
	Rubber seal	Nitrile / Silicone	
	Set-screw	Stainless steel	SUS410
Housing		Stainless cast steel	SCS13
Cover		Cold rolled stainless steel	SUS304
Grease nipple		Stainless steel	SUS303

NOMENCLATURE

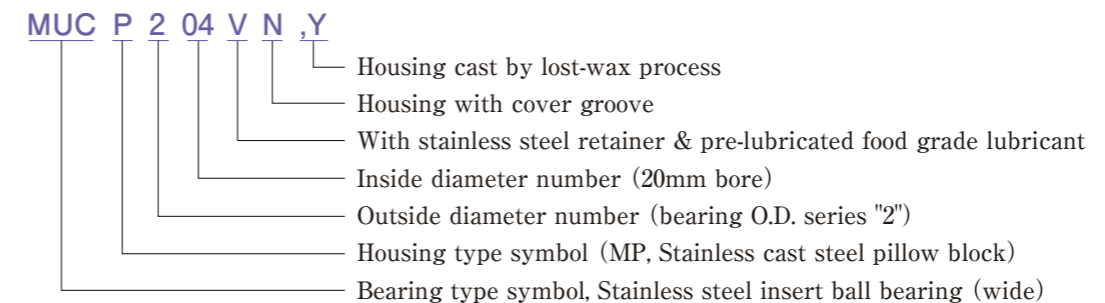

RANGE OF OPERATING TEMPERATURE

Bearing	Rubber seal	Lubricant	Operating temperature
MUC200V	Nitrile (NBR)	Clarion® Food Machinery HT EP Grease, No. 2 *	-10 ~ +100°C
MUC200V-C4HR20	Silicone	Clarion® Food Machinery HT EP Grease, No. 2 *	-10 ~ +150°C
MUC200V-CR2A	Silicone	Aero Shell 7 **	-40 ~ +100°C

* Clarion® Food Machinery HT EP # 2 Grease is food grade lubricant produced by CITGO Petroleum Corporation and approved as NSF (National Sanitation Foundation) H-1 grade. However, please handle it with care so that the grease does not come into contact with food.

** Aero Shell 7 grease is not food grade lubricant.

Add suffix "C4HR20" for heat-resistant stainless steel bearing lubricated with food grade grease.
Add suffix "CR2A" for cold-resistant stainless steel bearing.

CORROSION RESISTANCE

◎: Excellent - No effect ○: Good - Minor effect △: Fair - Moderate effect ×: Not recommended - Severe effect

Series	Material	Chemicals									
		Distilled water	Sewage	Seawater	Hydrochloric acid	Nitric acid	Sulfuric acid	Sodium hydroxide	Calcium hydroxide	Hydrogen peroxide	Methyl alcohol
MUCP	Stainless steel SUS440C(equiv.)	◎	○	△	×	×	×	○	○	○	○
	Stainless steel SUS304	◎	◎	◎	○	○	○	◎	◎	○	◎
	Stainless cast steel SCS13	◎	◎	◎	○	○	○	◎	◎	○	◎
UCP	High carbon chromium bearing steel SUJ2	○	△	×	×	×	×	×	×	×	×
	Gray cast iron FC200	○	△	×	×	×	×	×	×	×	×

Note: Applicable conditions of the above-mentioned chemicals (approx. 10% solution) do not mean "fully dipped-in" operation, but splashing each chemical solution over the bearing units.

RECOMMENDED TIGHTENING TORQUE FOR SET-SCREWS

Bearing No.	Hex key size	Recommended tightening torque (N·m)
MUC201V	2.5	2.4
MUC202V		
MUC203V		
MUC204V		
MUC205V		
MUC206V		
MUC207V	3	3.9
MUC208V		
MUC209V		
MUC210V	4	8.3
MUC211V		
MUC212V		
MUC213V	5	16.2

ALLOWABLE SPEED

Allowable dn value for MUC200V type is 100,000

dn = bore diameter d (mm) x operating speed n (rpm)

TOLERANCES

(1) TOLERANCES OF BEARINGS

Unit : μm

Inner ring								Outer ring				
Nominal bore dia. (mm)		Deviation of mean bore dia. in plane of inner ring (Δd_{mp})		Variation of bore dia. in plane of inner ring V_{dp}	Deviation of width ΔBs (reference)		Radial runout of inner ring K_{ia} (reference)	Nominal outside dia. (mm)		Deviation of mean outside dia. (ΔD_m)		Radial runout of outer ring K_{ea} (reference)
Over	Incl.	High	Low		High	Low	Max.	Over	Incl.	High	Low	Max.
10	18	+15	0	10	0	-120	15	30	50	0	-11	20
18	30	+18	0	12	0	-120	18	50	80	0	-13	25
30	50	+21	0	14	0	-120	20	80	120	0	-15	35
50	80	+24	0	16	0	-150	25					

(2) TOLERANCES OF HOUSINGS

Unit : μm

Housing No.	Pillow type	Flange type				Take-Up type				Symmetricity tolerance of both groove-side face X (Max.)
MP, MPA MF, MFL MFC MT	Deviation of distance from mounting face to centre of spherical seat	Positional tolerance of bolt hole X	Deviation of spigot joint outside diameter ΔH_{3s}		Deviation of raceway groove width ΔA_{1s}		Deviation of distance between both groove bottoms			
			High	Low	High	Low	ΔH_{1s}			
203 ~ 206 207 ~ 210	± 150	± 500	700	0	-46	+200	0	0	-500	500
211 ~ 213	± 200	± 800	1000	0	-63	-	-	-	-	-

SHAFT TOLERANCES

Recommended shaft tolerances are shown in the table below and the shaft must be straight without burrs.

Shaft dia. (mm)		Recommended shaft tolerances (μm)		
Over	Incl.	js7	h7	h8
10	18	± 9	0 ~ -18	0 ~ -27
18	30	± 10.5	0 ~ -21	0 ~ -33
30	50	± 12.5	0 ~ -25	0 ~ -39
50	80	± 15	0 ~ -30	0 ~ -46

Pillow Block Units MUCP200V,Y

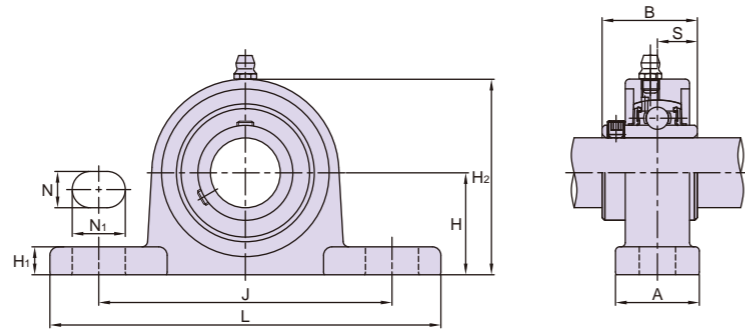
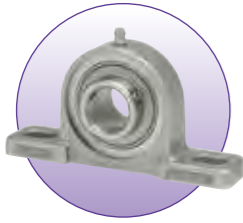

Shaft dia. (mm)	Unit No.	Dimensions (mm)											Bolt Size	
		H	L	A	J	N	N ₁	H ₁	H ₂	B	S	A ₄		A ₆
12	MUCP201V,Y	30.2	127	30	95	13	19	11	61	31	12.7	56	8	M10
15	MUCP202V,Y	30.2	127	30	95	13	19	11	61	31	12.7	56	8	M10
17	MUCP203V,Y	30.2	127	30	95	13	19	11	61	31	12.7	56	8	M10
20	MUCP204V,Y	33.3	127	30	95	13	19	11	65	31	12.7	56	8	M10
25	MUCP205V,Y	36.5	140	30	105	13	19	11	70	34.1	14.3	63	10	M10
30	MUCP206V,Y	42.9	165	36	121	17	21	10	83	38.1	15.9	65	9	M14
35	MUCP207V,Y	47.6	167	38	127	17	21	10	94	42.9	17.5	70	8	M14
40	MUCP208V,Y	49.2	184	40	137	17	22	10	100	49.2	19	82	10	M14
45	MUCP209V,Y	54	190	40	146	17	22	11	108	49.2	19	82	10	M14
50	MUCP210V,Y	57.2	206	45	159	20	25	11	114	51.6	19	87	9	M16
55	MUCP211V,Y	63.5	219	45	171	20	25	16	126	55.6	22.2	-	-	M16
60	MUCP212V,Y	69.8	241	50	184	20	25	19	138	65.1	25.4	-	-	M16
65	MUCP213V,Y	76.2	265	52	203	25	29	20	150	65.1	25.4	-	-	M20

Note : thread size of grease fitting is all 1/4-28UNF.

Four-Bolt Flange Units MUCF200V,Y

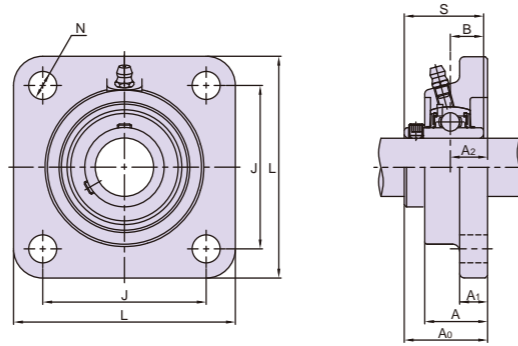

Shaft dia. (mm)	Unit No.	Dimensions (mm)											Bolt Size
		L	A	J	N	A ₁	A ₂	A ₀	B	S	A ₄	A ₆	
12	MUCF201V,Y	86	25.5	64	12	11	15	33.3	31	12.7	43	8	M10
15	MUCF202V,Y	86	25.5	64	12	11	15	33.3	31	12.7	43	8	M10
17	MUCF203V,Y	86	25.5	64	12	11	15	33.3	31	12.7	43	8	M10
20	MUCF204V,Y	86	25.5	64	12	11	15	33.3	31	12.7	43	8	M10
25	MUCF205V,Y	95	27	70	12	12	16	35.8	34.1	14.3	47	9	M10
30	MUCF206V,Y	108	31	83	12	12.5	18	40.2	38.1	15.9	51	9	M10
35	MUCF207V,Y	117	34	92	14	10.5	19	44.4	42.9	17.5	54	8	M12
40	MUCF208V,Y	130	36	102	16	11	21	51.2	49.2	19	62	10	M14
45	MUCF209V,Y	137	38	105	16	13	22	52.2	49.2	19	63	10	M14
50	MUCF210V,Y	143	40	111	16	13	22	54.6	51.6	19	66	9	M14
55	MUCF211V,Y	162	43	130	19	16	25	58.4	55.6	22.2	-	-	M16
60	MUCF212V,Y	175	48	143	19	16.5	29	68.7	65.1	25.4	-	-	M16
65	MUCF213V,Y	187	50	149	19	16.5	30	69.7	65.1	25.4	-	-	M16

Note : thread size of grease fitting is all 1/4-28UNF.

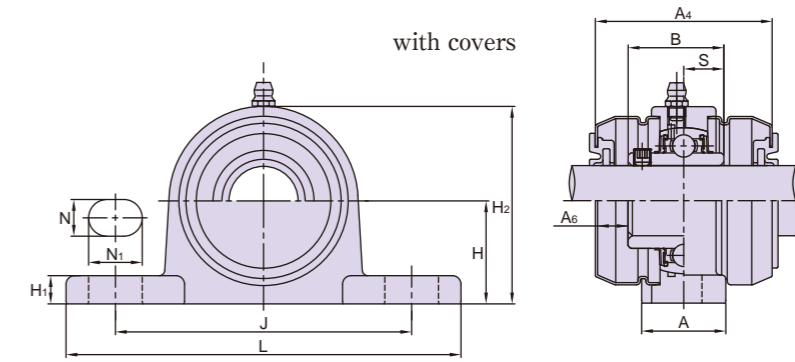

Bearing No.	Bearing		Housing No.		Unit No. with Covers		Weight (kg)	
	Basic Load Rating (kN)		Standard	With groove for covers	Open Cover	Closed Cover	Standard	With Covers
	Cr	Cor						
MUC201V	10.9	5.3	MP203,Y	MP203C,Y	MUCP201VC,Y	MUCP201VE,Y	0.62	0.68
MUC202V	10.9	5.3	MP203,Y	MP203C,Y	MUCP202VC,Y	MUCP202VE,Y	0.6	0.66
MUC203V	10.9	5.3	MP203,Y	MP203C,Y	MUCP203VC,Y	MUCP203VE,Y	0.59	0.65
MUC204V	10.9	5.3	MP204,Y	MP204C,Y	MUCP204VC,Y	MUCP204VE,Y	0.62	0.68
MUC205V	11.9	6.3	MP205,Y	MP205C,Y	MUCP205VC,Y	MUCP205VE,Y	0.68	0.76
MUC206V	16.7	9	MP206,Y	MP206C,Y	MUCP206VC,Y	MUCP206VE,Y	1.09	1.17
MUC207V	22	12.3	MP207,Y	MP207C,Y	MUCP207VC,Y	MUCP207VE,Y	1.47	1.67
MUC208V	24.9	14.3	MP208,Y	MP208C,Y	MUCP208VC,Y	MUCP208VE,Y	1.77	1.97
MUC209V	28.1	16.4	MP209,Y	MP209C,Y	MUCP209VC,Y	MUCP209VE,Y	2.04	2.24
MUC210V	30.2	18.6	MP210,Y	MP210C,Y	MUCP210VC,Y	MUCP210VE,Y	2.34	2.54
MUC211V	36.6	23.5	MP211,Y	MP211C,Y	-	-	3.05	-
MUC212V	44.6	28.9	MP212,Y	MP212C,Y	-	-	4.23	-
MUC213V	48.9	32	MP213,Y	MP213C,Y	-	-	5.02	-

Bearing No.	Bearing		Housing No.		Unit No. with Cover		Weight (kg)	
	Basic Load Rating (kN)		Standard	With groove for cover	Open Cover	Closed Cover	Standard	With Cover
	Cr	Cor						
MUC201V	10.9	5.3	MF204,Y	MF204C,Y	MUCF201VC,Y	MUCF201VE,Y	0.75	0.78
MUC202V	10.9	5.3	MF204,Y	MF204C,Y	MUCF202VC,Y	MUCF202VE,Y	0.73	0.76
MUC203V	10.9	5.3	MF204,Y	MF204C,Y	MUCF203VC,Y	MUCF203VE,Y	0.72	0.75
MUC204V	10.9	5.3	MF204,Y	MF204C,Y	MUCF204VC,Y	MUCF204VE,Y	0.7	0.73
MUC205V	11.9	6.3	MF205,Y	MF205C,Y	MUCF205VC,Y	MUCF205VE,Y	0.90	0.94
MUC206V	16.7	9	MF206,Y	MF206C,Y	MUCF206VC,Y	MUCF206VE,Y	1.27	1.31
MUC207V	22	12.3	MF207,Y	MF207C,Y	MUCF207VC,Y	MUCF207VE,Y	1.46	1.56
MUC208V	24.9	14.3	MF208,Y	MF208C,Y	MUCF208VC,Y	MUCF208VE,Y	1.93	2.03
MUC209V	28.1	16.4	MF209,Y	MF209C,Y	MUCF209VC,Y	MUCF209VE,Y	2.32	2.42
MUC210V	30.2	18.6	MF210,Y	MF210C,Y	MUCF210VC,Y	MUCF210VE,Y	2.63	2.73
MUC211V	36.6	23.5	MF211,Y	-	-	-	3.85	-
MUC212V	44.6	28.9	MF212,Y	-	-	-	4.97	-
MUC213V	48.9	32	MF213,Y	-	-	-	5.93	-

Two-Bolt Flange Units MUCFL200V,Y

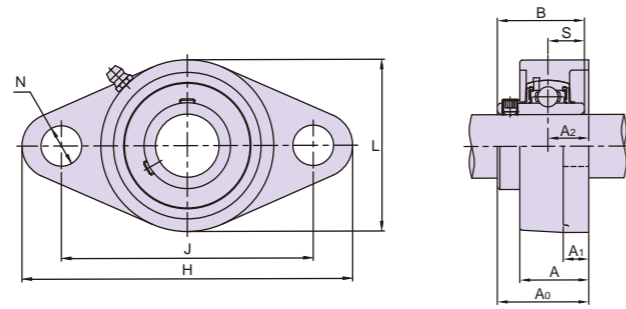
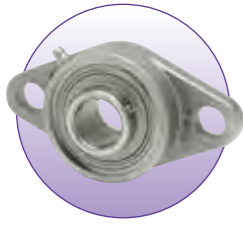

Shaft dia. (mm)	Unit No.	Dimensions (mm)												Bolt Size
		H	L	A	J	N	A ₁	A ₂	A ₀	B	S	A ₄	A ₆	
12	MUCFL201V,Y	113	60	25.5	90	12	10	15	33.3	31	12.7	43	8	M10
15	MUCFL202V,Y	113	60	25.5	90	12	10	15	33.3	31	12.7	43	8	M10
17	MUCFL203V,Y	113	60	25.5	90	12	10	15	33.3	31	12.7	43	8	M10
20	MUCFL204V,Y	113	60	25.5	90	12	10	15	33.3	31	12.7	43	8	M10
25	MUCFL205V,Y	130	68	27	99	16	10	16	35.8	34.1	14.3	47	9	M14
30	MUCFL206V,Y	148	80	31	117	16	10	18	40.2	38.1	15.9	51	9	M14
35	MUCFL207V,Y	161	90	34	130	16	11	19	44.4	42.9	17.5	54	8	M14
40	MUCFL208V,Y	175	100	36	144	16	11	21	51.2	49.2	19	62	10	M14
45	MUCFL209V,Y	188	108	38	148	19	13	22	52.2	49.2	19	63	10	M14
50	MUCFL210V,Y	197	115	40	157	19	13	22	54.6	51.6	19	66	9	M16

Note : thread size of grease fitting is all 1/4-28UNF.

Take-Up Units MUCT200V,Y

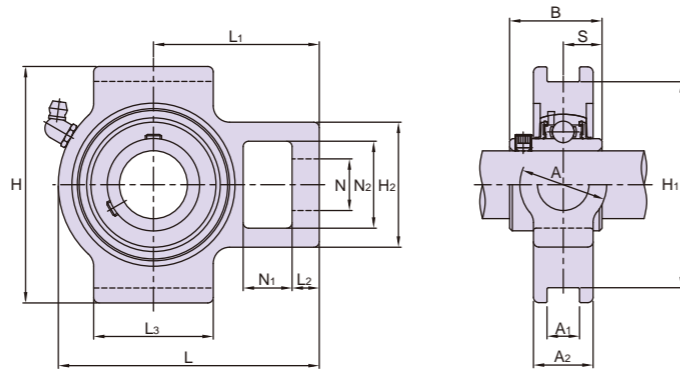

Shaft dia. (mm)	Unit No.	Dimensions (mm)																Bolt Size	
		A	A ₁	A ₂	H	H ₁	H ₂	L	L ₁	L ₂	L ₃	N	N ₁	N ₂	B	S	A ₄		A ₆
12	MUCT201V,Y	32	12	21	87	76	46	92	60	10	44	19	18	32	31	12.7	56	8	M10
15	MUCT202V,Y	32	12	21	87	76	46	92	60	10	44	19	18	32	31	12.7	56	8	M10
17	MUCT203V,Y	32	12	21	87	76	46	92	60	10	44	19	18	32	31	12.7	56	8	M10
20	MUCT204V,Y	32	12	21	87	76	46	92	60	10	44	19	18	32	31	12.7	56	8	M10
25	MUCT205V,Y	32	12	22	87	76	46	96	61	10	44	19	18	32	34.1	14.3	61	9	M14
30	MUCT206V,Y	36.5	12	27	101	89	52	111	69	10	50	22	18	37	38.1	15.9	65	9	M14
35	MUCT207V,Y	37	12	30	101	89	58	127	77	13	56	22	18	37	42.9	17.5	70	8	M14
40	MUCT208V,Y	49	16	33	113	102	74	142	87	16	72	29	20	49	49.2	19	82	10	M14
45	MUCT209V,Y	49	16	34	116	102	74	143	87	16	72	29	20	49	49.2	19	82	10	M14
50	MUCT210V,Y	49	16	37	116	102	74	147	89	16	72	29	20	49	51.6	19	87	9	M16

Note : thread size of grease fitting is all 1/4-28UNF.

with cover

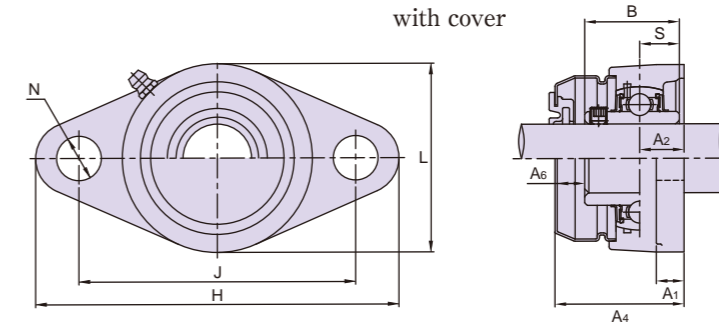

Bearing No.	Bearing		Housing No.		Unit No. with Cover		Weight (kg)	
	Basic Load Rating (kN)		Standard	With groove for cover	Open Cover	Closed Cover	Standard	With Cover
	Cr	Cor						
MUC201V	10.9	5.3	MFL204,Y	MFL204C,Y	MUCFL201VC,Y	MUCFL201VE,Y	0.51	0.54
MUC202V	10.9	5.3	MFL204,Y	MFL204C,Y	MUCFL202VC,Y	MUCFL202VE,Y	0.49	0.52
MUC203V	10.9	5.3	MFL204,Y	MFL204C,Y	MUCFL203VC,Y	MUCFL203VE,Y	0.48	0.51
MUC204V	10.9	5.3	MFL204,Y	MFL204C,Y	MUCFL204VC,Y	MUCFL204VE,Y	0.46	0.49
MUC205V	11.9	6.3	MFL205,Y	MFL205C,Y	MUCFL205VC,Y	MUCFL205VE,Y	0.59	0.63
MUC206V	16.7	9	MFL206,Y	MFL206C,Y	MUCFL206VC,Y	MUCFL206VE,Y	0.91	0.95
MUC207V	22	12.3	MFL207,Y	MFL207C,Y	MUCFL207VC,Y	MUCFL207VE,Y	1.21	1.31
MUC208V	24.9	14.3	MFL208,Y	MFL208C,Y	MUCFL208VC,Y	MUCFL208VE,Y	1.59	1.69
MUC209V	28.1	16.4	MFL209,Y	MFL209C,Y	MUCFL209VC,Y	MUCFL209VE,Y	1.96	2.06
MUC210V	30.2	18.6	MFL210,Y	MFL210C,Y	MUCFL210VC,Y	MUCFL210VE,Y	2.31	2.41

with covers

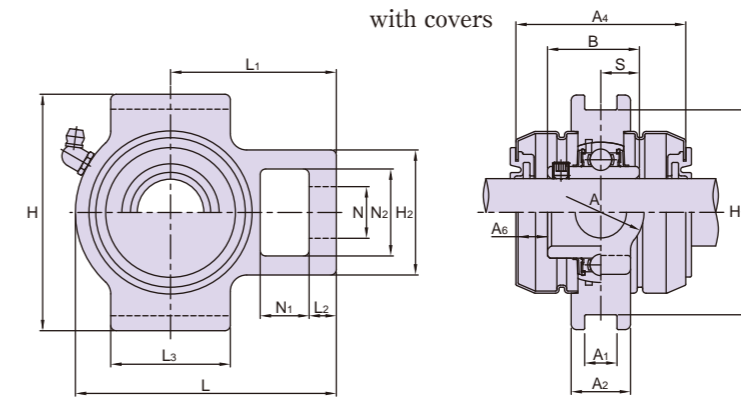

Bearing No.	Bearing		Housing No.		Unit No. with Covers		Weight (kg)	
	Basic Load Rating (kN)		Standard	With groove for covers	Open Cover	Closed Cover	Standard	With Covers
	Cr	Cor						
MUC201V	10.9	5.3	MT204,Y	MT204C,Y	MUCT201VC,Y	MUCT201VE,Y	0.74	0.80
MUC202V	10.9	5.3	MT204,Y	MT204C,Y	MUCT202VC,Y	MUCT202VE,Y	0.72	0.78
MUC203V	10.9	5.3	MT204,Y	MT204C,Y	MUCT203VC,Y	MUCT203VE,Y	0.71	0.77
MUC204V	10.9	5.3	MT204,Y	MT204C,Y	MUCT204VC,Y	MUCT204VE,Y	0.69	0.75
MUC205V	11.9	6.3	MT205,Y	MT205C,Y	MUCT205VC,Y	MUCT205VE,Y	0.72	0.8
MUC206V	16.7	9	MT206,Y	MT206C,Y	MUCT206VC,Y	MUCT206VE,Y	1.16	1.24
MUC207V	22	12.3	MT207,Y	MT207C,Y	MUCT207VC,Y	MUCT207VE,Y	1.54	1.74
MUC208V	24.9	14.3	MT208,Y	MT208C,Y	MUCT208VC,Y	MUCT208VE,Y	2.26	2.46
MUC209V	28.1	16.4	MT209,Y	MT209C,Y	MUCT209VC,Y	MUCT209VE,Y	2.21	2.41
MUC210V	30.2	18.6	MT210,Y	MT210C,Y	MUCT210VC,Y	MUCT210VE,Y	2.35	2.55

Tapped Base Pillow Block Units MUCPA200V,Y

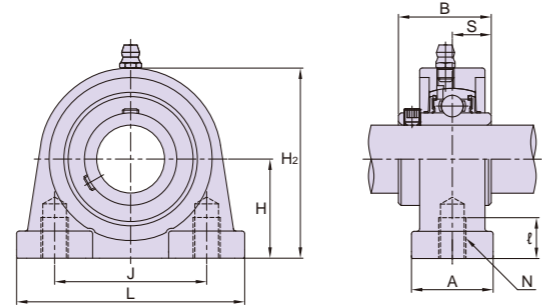

Shaft dia. (mm)	Unit No.	Dimensions (mm)										
		H	L	A	J	N	l	H ₂	B	S	A ₄	A ₆
12	MUCPA201V,Y	30.2	76	25.5	52	M10x1.5	12	60.9	31	12.7	55	8
15	MUCPA202V,Y	30.2	76	25.5	52	M10x1.5	12	60.9	31	12.7	55	8
17	MUCPA203V,Y	30.2	76	25.5	52	M10x1.5	12	60.9	31	12.7	55	8
20	MUCPA204V,Y	30.2	76	25.5	52	M10x1.5	12	60.9	31	12.7	55	8
25	MUCPA205V,Y	36.5	84	30	56	M10x1.5	15	70	34.1	14.3	63	10
30	MUCPA206V,Y	42.9	94	34	66	M14x2	18	82	38.1	15.9	65	9

Note : thread size of grease fitting is all 1/4-28UNF.

Flange Cartridge Units MUCFC200V,Y

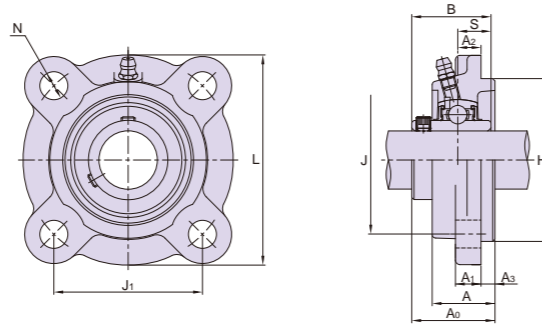
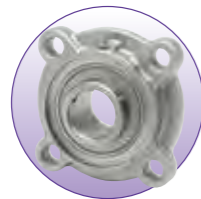

Shaft dia. (mm)	Unit No.	Dimensions (mm)														Bolt Size
		L	A	J	J ₁	N	A ₀	A ₁	A ₂	A ₃	H ₃	B	S	A ₄	A ₆	
12	MUCFC201V,Y	80	25.5	78	55.1	12	33.3	11	10	5	62	31	12.7	43	8	M10
15	MUCFC202V,Y	80	25.5	78	55.1	12	33.3	11	10	5	62	31	12.7	43	8	M10
17	MUCFC203V,Y	80	25.5	78	55.1	12	33.3	11	10	5	62	31	12.7	43	8	M10
20	MUCFC204V,Y	80	25.5	78	55.1	12	33.3	11	10	5	62	31	12.7	43	8	M10
25	MUCFC205V,Y	90	27	90	63.6	12	35.8	11	10	6	70	34.1	14.3	47	9	M10
30	MUCFC206V,Y	100	31	100	70.7	12	40.2	13	10	8	80	38.1	15.9	51	9	M10
35	MUCFC207V,Y	110	34	110	77.8	14	44.4	13.5	11	8	90	42.9	17.5	54	8	M12
40	MUCFC208V,Y	120	36	120	84.8	14	51.2	13.5	11	10	100	49.2	19	62	9	M12

Note : thread size of grease fitting is all 1/4-28UNF.

Insert Ball Bearings MUC200V MUC200V-C4HR20 MUC200V-CR2A



Shaft dia. (mm)	Unit No.	Dimensions (mm)											Basic Load Rating (kN)		Weight (kg)
		d	D	B	C	r _{Smin}	S	S ₁	S ₂	ds	C ₁	d ₄	Cr	Cor	
12	MUC201V	12	47	31	17	0.6	12.7	18.3	5	M5x0.8	4.5	29	10.9	5.3	0.21
15	MUC202V	15	47	31	17	0.6	12.7	18.3	5	M5x0.8	4.5	29	10.9	5.3	0.19
17	MUC203V	17	47	31	17	0.6	12.7	18.3	5	M5x0.8	4.5	29	10.9	5.3	0.18
20	MUC204V	20	47	31	17	1	12.7	18.3	5	M5x0.8	4.5	29	10.9	5.3	0.16
25	MUC205V	25	52	34.1	17	1	14.3	19.8	5	M5x0.8	4.5	34	11.9	6.3	0.19
30	MUC206V	30	62	38.1	19	1	15.9	22.2	5	M5x0.8	5.1	40.5	16.7	9	0.31
35	MUC207V	35	72	42.9	20	1.5	17.5	25.4	7	M6x0.75	5.8	48	22	12.3	0.48
40	MUC208V	40	80	49.2	21	1.5	19	30.2	8	M6x0.75	6.2	53	24.9	14.3	0.62
45	MUC209V	45	85	49.2	22	1.5	19	30.2	8	M6x0.75	6.5	57.3	28.1	16.4	0.67
50	MUC210V	50	90	51.6	23	1.5	19	32.6	9	M8x1	6.5	63	30.2	18.6	0.78
55	MUC211V	55	100	55.6	24	2	22.2	33.4	9	M8x1	7.3	70	36.6	23.5	1.03
60	MUC212V	60	110	65.1	26	2	25.4	39.7	10	M10x1.25	7.7	77	44.6	28.9	1.45
65	MUC213V	65	120	65.1	27	2	25.4	39.7	10	M10x1.25	8.3	82.1	48.9	32	1.71

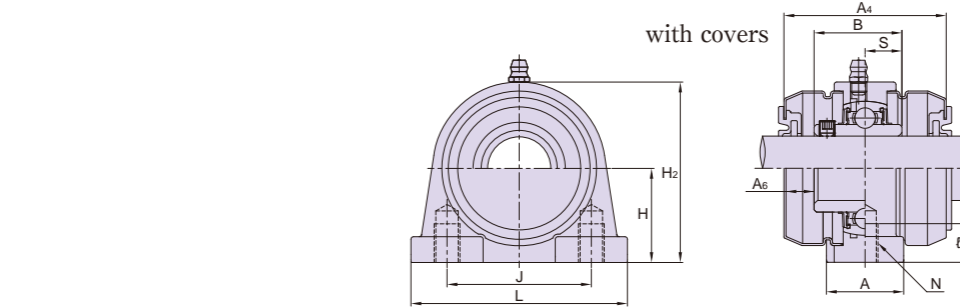
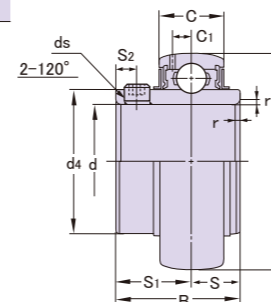

Bearing No.	Bearing		Housing No.		Unit No. with Covers		Weight (kg)	
	Basic Load Rating (kN)		Standard	With groove for covers	Open Cover	Closed Cover	Standard	With Covers
	Cr	Cor						
MUC201V	10.9	5.3	MPA204,Y	MPA204C,Y	MUCPA201VC,Y	MUCPA201VE,Y	0.49	0.55
MUC202V	10.9	5.3	MPA204,Y	MPA204C,Y	MUCPA202VC,Y	MUCPA202VE,Y	0.47	0.53
MUC203V	10.9	5.3	MPA204,Y	MPA204C,Y	MUCPA203VC,Y	MUCPA203VE,Y	0.46	0.52
MUC204V	10.9	5.3	MPA204,Y	MPA204C,Y	MUCPA204VC,Y	MUCPA204VE,Y	0.44	0.5
MUC205V	11.9	6.3	MPA205,Y	MPA205C,Y	MUCPA205VC,Y	MUCPA205VE,Y	0.63	0.71
MUC206V	16.7	9	MPA206,Y	MPA206C,Y	MUCPA206VC,Y	MUCPA206VE,Y	0.96	1.04

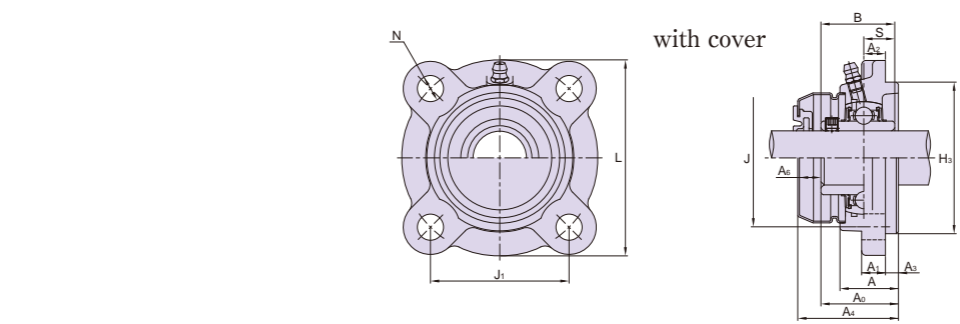

Bearing No.	Bearing		Housing No.		Unit No. with Cover		Weight (kg)	
	Basic Load Rating (kN)		Standard	With groove for cover	Open Cover	Closed Cover	Standard	With Cover
	Cr	Cor						
MUC201V	10.9	5.3	MFC204,Y	MFC204C,Y	MUCFC201VC,Y	MUCFC201VE,Y	0.56	0.59
MUC202V	10.9	5.3	MFC204,Y	MFC204C,Y	MUCFC202VC,Y	MUCFC202VE,Y	0.54	0.57
MUC203V	10.9	5.3	MFC204,Y	MFC204C,Y	MUCFC203VC,Y	MUCFC203VE,Y	0.53	0.56
MUC204V	10.9	5.3	MFC204,Y	MFC204C,Y	MUCFC204VC,Y	MUCFC204VE,Y	0.51	0.54
MUC205V	11.9	6.3	MFC205,Y	MFC205C,Y	MUCFC205VC,Y	MUCFC205VE,Y	0.66	0.7
MUC206V	16.7	9	MFC206,Y	MFC206C,Y	MUCFC206VC,Y	MUCFC206VE,Y	0.91	0.95
MUC207V	22	12.3	MFC207,Y	MFC207C,Y	MUCFC207VC,Y	MUCFC207VE,Y	1.19	1.29
MUC208V	24.9	14.3	MFC208,Y	MFC208C,Y	MUCFC208VC,Y	MUCFC208VE,Y	1.54	1.64

Stainless Steel Covers 200CPS00 200CPES

Shaft dia. (mm)	Open Cover	Closed Cover	Dimensions (mm)			
			d	R	B	t
20	204CPS20	204CPES	19.5	54	20	0.8
25	205CPS25	205CPES	24.5	60	23	0.8
30	206CPS30	206CPES	29.5	70	23	0.8
35	207CPS35	207CPES	34.5	80	25	0.8
40	208CPS40	208CPES	39.5	88	30	0.8
45	209CPS45	209CPES	44.5	95	30	0.8
50	210CPS50	210CPES	49.5	100	32	1.0

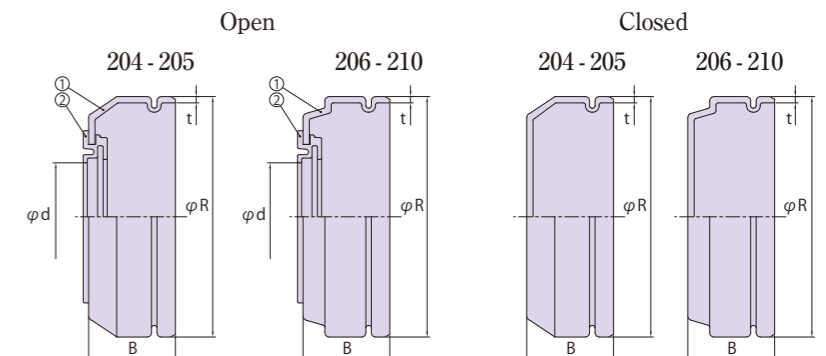

Contact Us For More Information.

SLS Bearings (S) Pte Ltd

5 Tuas South Street 15, Singapore 636907

www.slsbearings.com

Visit SLS e-shop : shop.slsbearings.com/sg

Phone : (65) 6515 0515

Email : contact.us@slsbearings.com.sg

ASAHI SEIKO CO., LTD.

<http://www.asahiseiko.co.jp>

FOREIGN TRADE DEPARTMENT : 570-1, Otori-Higashi-machi 6-cho, Nishi-ku, Sakai City, Osaka 593-8324, Japan

Tel : +81-72-272-6900

Fax : +81-72-272-6903

E-mail : info@asahiseiko.co.jp

U.S.A. OFFICE : 570 North Wheeling Road, Mount Prospect, Illinois 60056, U.S.A.

Tel : +1-847-759-0620

Fax : +1-847-759-0630

CHINA OFFICE : ROOM#101, Xuyuan Building, #5003, Longgang Road, Longgang District, Shenzhen City, Guangdong Province, 518116, China

Tel : +86-755-23605700 / 23902930

Fax : +86-755-83376159

HEAD OFFICE & FACTORY : 570-1, Otori-Higashi-machi 6-cho, Nishi-ku, Sakai City, Osaka 593-8324, Japan

Tel : +81-72-271-1221

Fax : +81-72-273-0058